

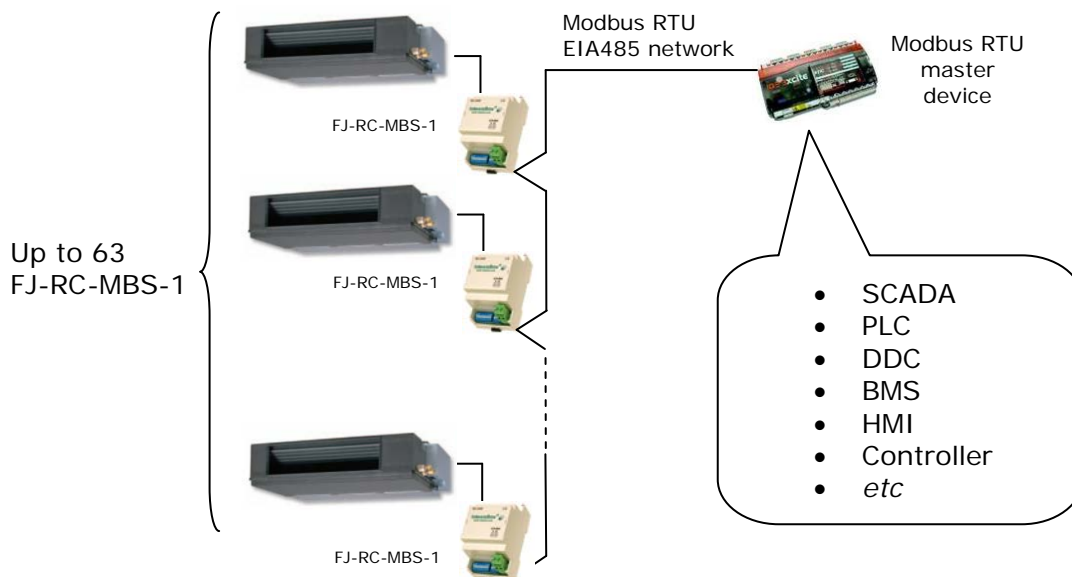

IntesisBox® FJ-RC-MBS-1

Modbus interface for FUJITSU air conditioners



The FJ-RC-MBS-1 interface allows a complete and natural integration of **FUJITSU** air conditioners into Modbus RTU (EIA485) networks.

- Reduced dimensions. 93 x 53 x 58 mm.
- Quick and easy installation.
Mountable on DIN rail, wall, or even inside the indoor unit in some models of AC.
- External power not required.
- Direct connection to Modbus RTU (EIA485) networks. Up to 63 FJ-RC-MBS-1 devices can be connected in the same network. *FJ-RC-MBS-1 is a Modbus slave device.*
- Direct connection to the AC indoor units.
- Configuration from both on-board DIP-switches and Modbus RTU.
- Total Control and Supervision.
- Real states of the AC unit's internal variables.
- Allows using simultaneously the IR and wired remote controls and Modbus RTU.

1. Modbus Interface

1.1 Modbus functions

FJ-RC-MBS-1 implements the following standard Modbus functions:

- 3: Read Holding Registers
- 4: Read Input Registers
- 6: Write Single Register
- 16: Write Multiple Registers (Although this function is allowed, the interface does not allow write operations of more than 1 register with the same request, this means that *length* field should always be 1 when using this function for writes)

The maximum number of registers that can be read in a single request is 100.

1.2 Modbus Communication parameters

FJ-RC-MBS-1 implements a Modbus RTU (slave) interface, to be connected to an EIA485 line. The communication parameters are:

- 8N2 communication (8 data bits, no parity and 2 stop bits)
- Configurable baudrates:
 - 2400 bps
 - 4800 bps
 - 9600 (default)
 - 19200

2. Connection

The FJ-RC-MBS-1 can be used with a **FUJITSU** Remote Controllers or without them. Use the EIA485 connector in the FJ-RC-MBS-1 to connect to the Modbus network.

- FJ-RC-MBS-1 with FUJITSU wired Remote Controller

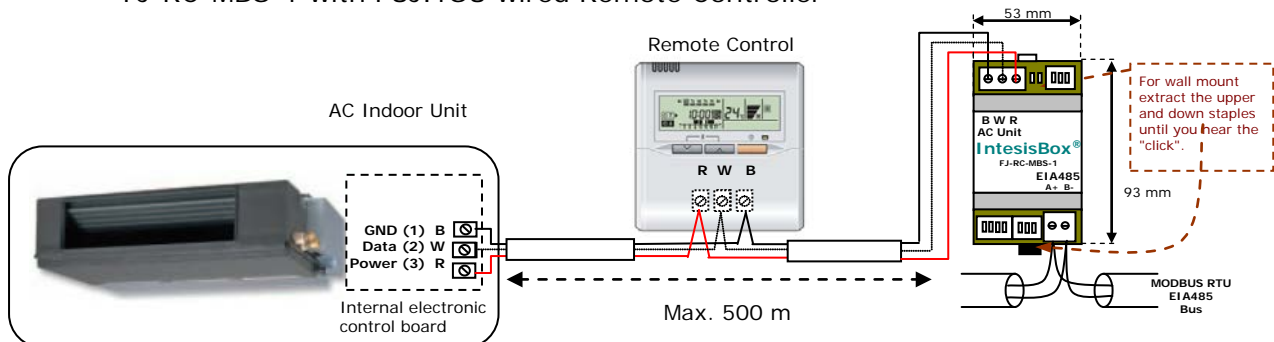

- FJ-RC-MBS-1 without FUJITSU wired Remote Controller

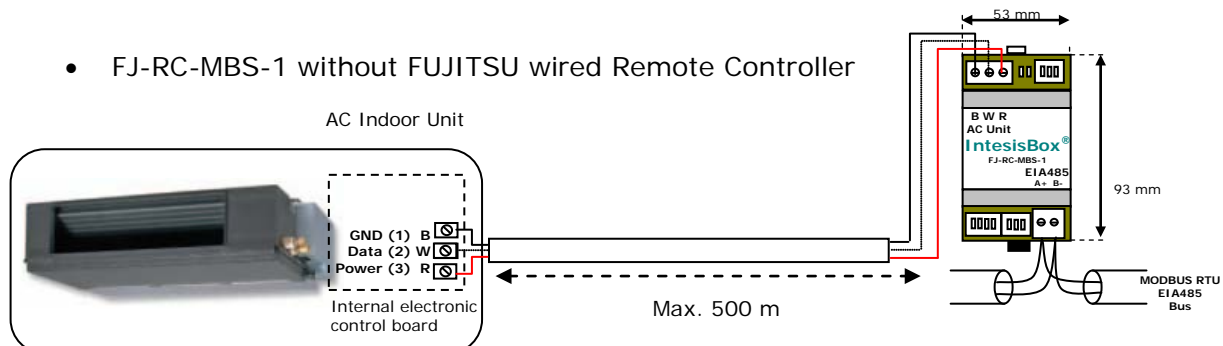

3. List of compatible FUJITSU AC indoor units

A list of FUJITSU indoor unit model references compatible with FJ-RC-MBS-1 and their available features can be found in:

http://www.intesis.com/pdf/IntesisBox_FJ-RC-xxx-1_AC_Compatibility.pdf

4. Technical Specifications

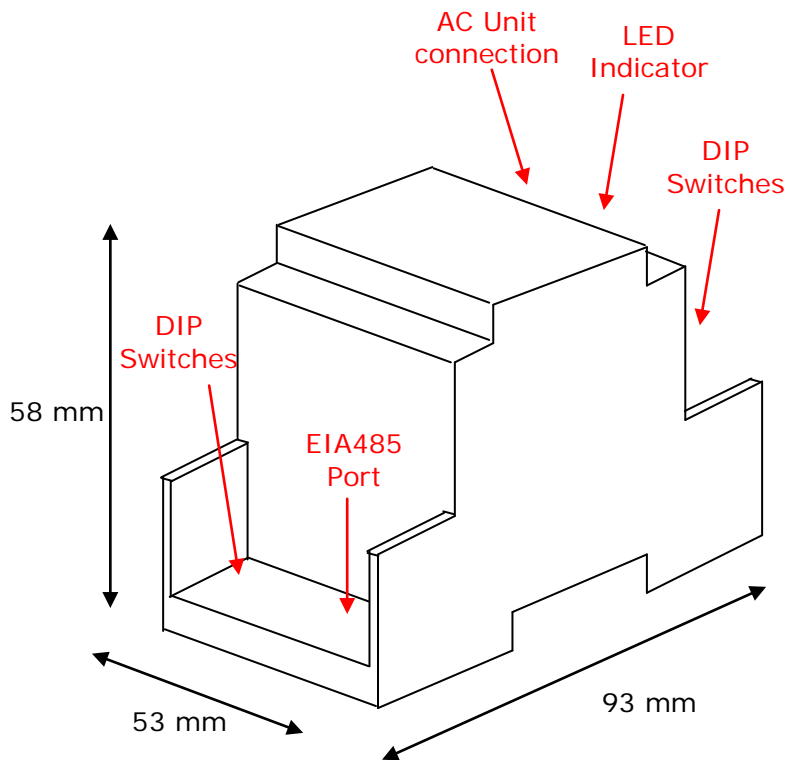

Dimensions:	93 x 53 x 58 mm
Weight:	85 g
Consumption Current:	80 mA
Operating Temperature:	0 . . . 40°C
Stock Temperature:	-40 . . . 85°C
Operating Humidity:	< 95% RH, non-condensing
Stock Humidity:	< 95% RH, non-condensing
Isolation voltage:	1000 VDC
Isolation resistance:	1000 MΩ
Modbus Media:	Compatible with Modbus RTU - EIA485 networks