

FV-08WQ1 70 CFM



Exterior Hood included



- Super quiet operation
 - ENERGY STAR® qualified
 - Totally enclosed condenser motor for long life —rated for 30,000 hours continuous run
 - Easy installation
- Rustproof paint treatment on galvanized housing
 - Built-in damper to prevent backdraft
 - Contemporary grille design
 - UL listed for tub/shower enclosure when used with a GFCI branch circuit wire
 - Thermal fuse protection
 - ASHRAE 62.2, LEED for Homes, ENERGY STAR IAP, CA Title 24, EarthCraft and WA Ventilation Code compliant
 - Hood with backdraft damper included
 - 3 year warranty

WhisperWall		FV-08WQ1
Characteristics (HVI Certified Data for 0.1" S.P.)	Static pressure in inches w. g.	0.03
	Air Volume (CFM)	70
	Noise (sones)	1.1
	Power Consumption (Watts)	18
	Energy Efficiency (CFMs/Watt)	3.9
	Speed	660
	Current	0.20
	Power Rating (V/Hz)	120/60
	ENERGY STAR Qualified	Yes
	Installation	Duct Diameter (inches)
Sleeve Extension (inches)		up to 10
Wall Cap Included	Bird Screen	Yes
	Spring Damper	Yes
	Painted Galvanized	Yes
	Grille Size (inches sq.)	10-1/4
Approved Code/ Standard/ Regulation	UL Tub/Shower Enclosure	Yes
	Washington State VIAQ Code	Yes
	Mfg in ISO 9001 Certified Facility	Yes

Complete Specifications on pages 48-49.
Performance Curves on pages 40-47.

N/A=not applicable
w.g.=water gauge
S.P.=static pressure

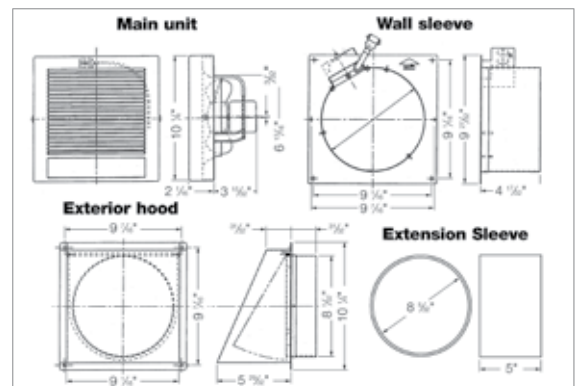
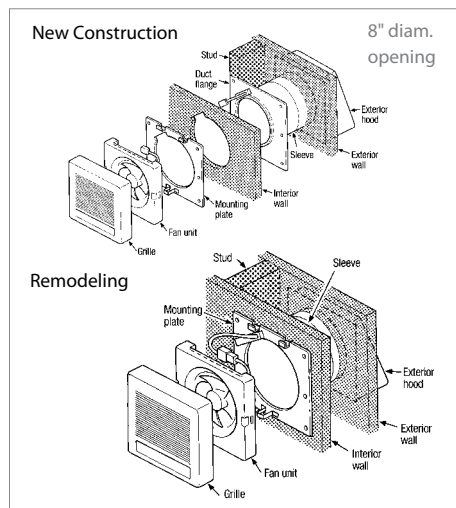

FV-08WQ1